

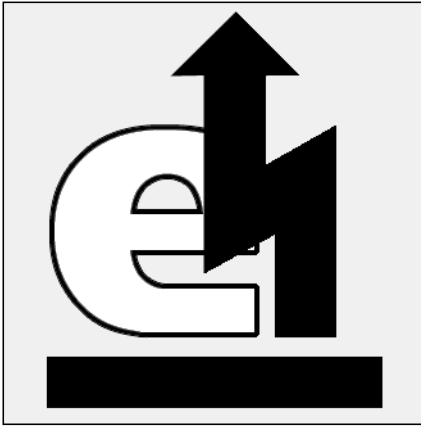

Schémas électrique et hydraulique  
Schemi elettrico e idraulico  
Esquema eléctrico y hidráulico  
Electric and hydraulic diagrams  
Elektro- und Hydraulikschema

---



La protection de l'installation doit être conforme aux normes en vigueur.  
 La protezione dell'installazione deve essere in conformità alle norme in vigore.  
 La protección de la instalación debe ser en conformidad con las normas en vigor.  
 Protection of the installation must comply with the actual norms.  
 Der Schutz der Anlage muss den geltenden Normen entsprechen.  
 Bescherming van de installatie moet in overeenstemming volgens de normen die van kracht zijn.

Chaudière / Caldaia / Caldera / Boiler / Kessel / Ketel

Mise à la terre conformément au réseau local / Messa a terra in conformità alla rete locale  
 Puesta a tierra en conformidad con la red local / Earthing in accordance with the local regulation  
 Erdung nach örtlichen Vorschriften / Aarding in overeenstemming met het plaatselijk net

F1	S6	H6 (OPTION)	P4/P5 (OPTION)	S7
Th./pr. sécurité	Limiteur	Panne	Compteur horaire	2 allures
Termostado di sicurezza	Limitadore	Inconveniente	Contaore	2 stadi
Limitador de sobrecalentamiento	Limitador	Fallo	Contador horario	2 etapas
Safety limiter	Limiter	Trouble	Running hors meter	2 stages
Sicherheitsbegrenzer	Begrenzer	Störung	Betriebsstundenzähler	2 Stufig
Beveiling thermostaat	Beperkingthermostaat	Storing	Uurteller	2 trap

Tri 400V 50Hz

230 V~ 50Hz

L1 L2 L3

L N

Q1

10A

Brûleur  
 Bruciatore  
 Quemador  
 Burner  
 Brenner  
 Brander

K1

/2.8

F12

197 95

98 96

/2.8

U V W PE

M1

3~

RS 232

DB9

A4

AFFICHEUR

SG5XX

A1

8

C

D

E

F

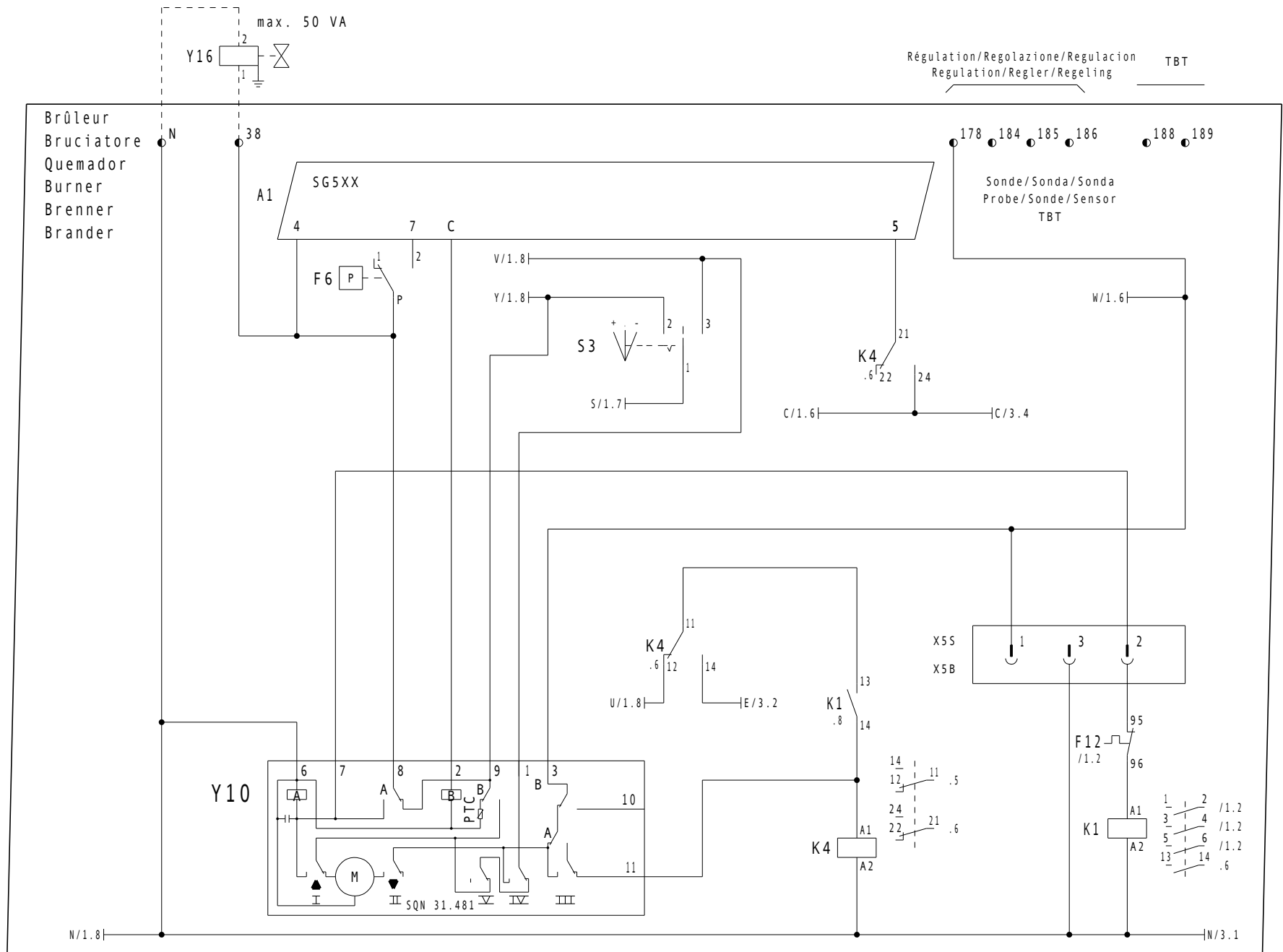

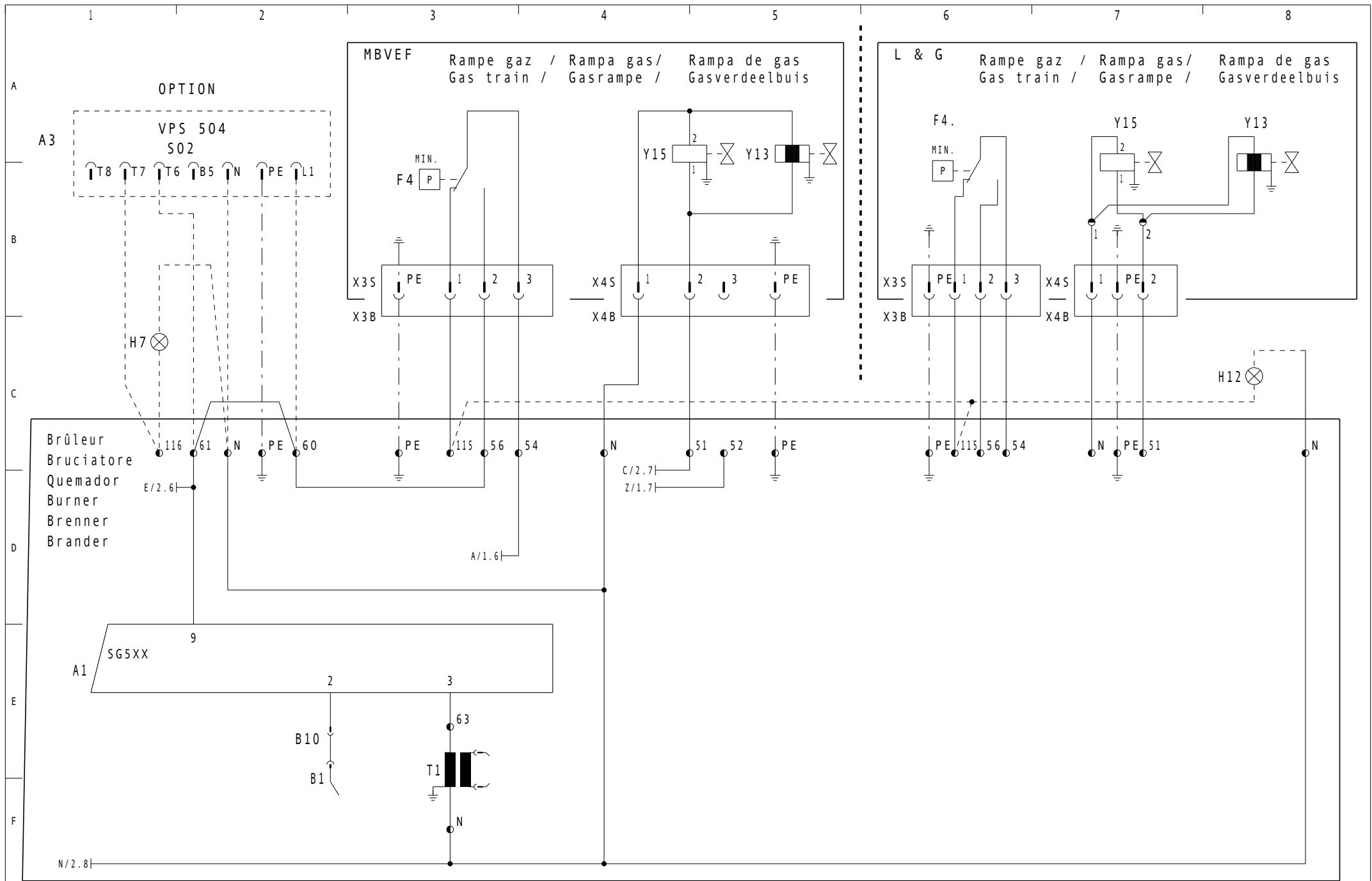

	1	2	3	4	5	6	7	8
A	"FR"	"IT"	"ES"	"GB"	"DE"	"NL"		
	A1	Coffret de contrôle	Programmatore di comando	Caja de mando y seguridad	Control and safety unit	Feuerungsautomat	Bedienings en veiligheidskoffer	
	A3	Contrôle d'étanchéité	Controllo della tenuta	Control de estanqueidad	Tightness controller	Dichtheitskontrollgerät	Afdichtingscontrole	
	A4	Afficheur	Visualizzatore	Pantalla de visualización	Display	Anzeigevorrichtung	Uitlezing	
B	B1	Electrode d'ionisation	Elettrodo d'ionizzazione	Electrodo de ionizacion	Ionisation electrode	Ionisationselektrode	Ionisatie-elektrode	
	B10	Pont de mesure	Ponte di misura	Puente de medicion	Current bridge	Messbruecke	Meetbrug	
	F4	Manostat gaz min.	Pressostato gas	Presostato de gas	Min gas pressure switch	Gasdruckwächter min.	Gaspressostaat	
	F6	Manostat d'air	Pressostato aria	Presostato de aire	Air pressure switch	Luftdruckwächter	Luchtpressostaat	
	F10	Fusible	Fusibile	Fusible	Control fuse	Sicherung	Zekering	
	F12	Protection thermique M1	Protezione termica M1	Proteccion termica M1	Thermal protection M1	Wärmeschutz M1	Thermische bescherming M1	
C	H7	Défaut étanchéité	Difetto di tenuta	Fallo de estanqueidad	Tightness fault	Dichtheitsmangel	Afdichtingsfout	
	H12	Manque de gaz	Mancanza del gas	Ausencia de gas	Gas lack	Gasmangel	Gasgebrek	
	K..	Contacteur/relais	Contattore/relè	Contacto/relé	Contactor/relay	Schalter/Relais	Contactor/relais	
	M1	Moteur du brûleur	Motore del bruciatore	Motor del quemador	Burner motor	Brennermotor	Brandermotor	
	S1/H10	Marche/arrêt	Acceso/spento	Marcha/Parada	On/off	Ein/Aus	Aan/Uit	
	S2	Inter. man.-auto.	Interr. man/auto	Interruptor manual/auto	Man./auto. response	Wahlschalter man.-autom.	Schakelaar man./auto	
	S3	Inter. +/-	Interr. +/-	Interruptor +/-	+/- switch	Schalter +/-	Schak. +/-	
D	S5/H6	Déverouillage	Sbloccaggio	Desbloqueo	Reset	Fernentr.	Ontgrendeling	
	S28	Inter. Télécommande/local	Interr. Telecomando/locale	Inter. telemando/local	Local/remote control inter.	Inter-Fernsteuerung / Ort	Schakelaar Afstandsbediening/lokaal	
	T1	Transfo.	Trasformatore	Transformador de encendido	Ignition transfo.	Zündtrafo.	Ontstekingstransformator	
	Y10	Servomoteur	Servomotore	Servomotor	Damper motor	Stellantrieb	Servomotor	
	Y13	Vanne gaz principale	Valvola principale gas	Valvula de gas principal	Gas valve burner side	Gasventil gasseitig	Hoofdafsluiter gas	
	Y15	Vanne gaz de sécurité	Valvola sicurezza gas	Valvula de seguridad de gas	Safety gas valve	Sicherheitsgasventil	Veiligheidsafsluitergas	
E	Y16	Vanne de protection	Valvola di protezione	Valvula de proteccion	Protection valve	Schutzventil	Beschermingsafsluiter	
	296/297	M/A par télécommande	Acceso/spento con telecomando	Marcha/Parada mediante telemando	ON/OFF by remote control	Ein/Aus ferngesteuert	Aan/Uit met afstandsbesturing	
F								
Am : 9853		Date : 25.02.03	Visa : cod	Art. N°: 13013484.A	N° de schéma : G03.1.0297	Page : 4 / 5		

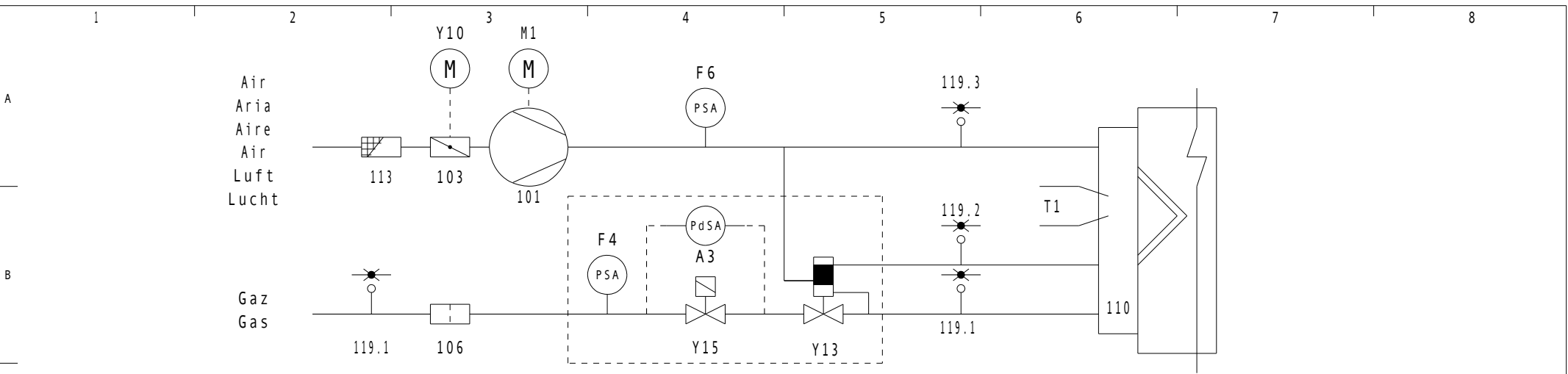

A3 OPTION	Controle d'étanchéité	Controllo della tenuta	Control de estanqueidad	Tightness control	Dichtheitskontrollgerät	Afdichtingscontrole
F4	Manostat gaz min.	Pressostato gas	Presostato de gas	Min gas pressure	Gasdruckwacher min.	Gaspressostaat
F6	Manostat d'air	Pressostato aria	Presostato de aire	Air pressure	Luftdruckwacher	Luchtpressostaat
M1	Moteur du bruleur	Motore del bruciatore	Motor del quemador	Burner motor	Brennermotor	Brandermotor
T1	Transfo.	Trasformatore	Transformador de encendido	Ignition transfo.	Zundrafo.	Ontstekings- transformator
Y10	Servomoteur	Servomotore	Servomotor	Damper motor	Stellantrieb	Servomotor
Y13	Vanne gaz principale	Valvola principale gas	Valvula de gas principal	Gas valve burner side	Gasventil gasseitig	Hoofdafsluiter gas
Y15	Vanne gaz de sécurité	Valvola sicurezza gas	Valvula de seguridad de gas	Safety gas valve	Sicherheitsgasventil	Veiligheidsafsluiter gas
101	Ventilateur	Ventilatore	Ventilador	Impeller	Ventilator	Ventilator
103	Volet d'air	Serranda aria	Trampilla de aire	Air-damper	Luftklappe	Luchtklep
106	Filtre	Filtro	Filtro	Filter	Filter	Filter
110	Injecteur gaz	Ugello gas	Inyector de gas	Gas injector	Gasinjektor	Gasinjector
113	Grille d'aspiration	Scatola dell'aria	Caja de aire	Protection	Ansauggitter	Luchthuis
119.1	Prise pression gaz	Presa presione gas	Toma de presion gas	Pressure pickup Gas	Messnippel Gas	Meetnippel Gas
119.2	Prise pression foyer	Presa pressione focolare	Toma presión hogar	Pressure pickup furnace	Messnippel Feuerraum	Drukmeetnippel haard
119.3	Prise pression air	Presa presione aria	Toma de presion aire	Pressure pickup air	Messnippel Luft	Meetnippel Lucht